

VeraPhase® 6000

High Precision Full GNSS Spectrum Antenna



Scientific



Reference
Network Stations



KEY FEATURES

- ▶ **Low axial ratios from horizon to horizon**
- ▶ **Very Tight Phase Center Variation (<1 mm / 0.03 in)**
- ▶ **Low current (45mA)**
- ▶ **Invariant performance from: +2.7 to 24 VDC**

The patented VeraPhase® 6000 antenna, powered by Tallysman, is a full GNSS spectrum antenna including L-band for correction services. It has consistent performance (gain, axial ratio, PCV, and PCO) across the full bandwidth. It provides the lowest axial ratios (horizon to horizon, over all azimuths) across all GNSS frequencies.

BENEFITS

- Consistent performance across all frequencies
- Broadest tracking elevation (0° - 180°)
- Extreme precision
- Excellent multipath rejection
- IP67, REACH, RoHS, WEEE compliant

VeraPhase® 6000

FEATURES

GNSS Frequencies

L-Band (MSS)	
GPS	L1, L2, L5
GLONASS	L1, L2, L3
Galileo	E1, E5a, E5b, E6
BeiDou	B1, B2, B3
SBAS	L1, L5
IRNSS	L5
QZSS	L1, L2, L5, L6

Polarisation

RHCP

Axial Ratio

< 0.5 db at zenith

Radiation Coverage (dBic)

	L1	L2
Zenith	6.7	5.8
15° elevation	-3.5	-1.7
10° elevation	-4.3	-2.6
5° elevation	-5.5	-3.5
Horizon	-6.6	-4.4

Amplifier

LNA Gain Flatness	1.5 dB over frequency range
Noise Figure	2.0 dB typ. At 25° C / 77° F
Input Voltage	+2.7 to +24 VDC nominal
Current	<45 mA (50 dB gain)
Impedance	50 Ω
VSWR	<1.5:1 max.
Available LNA Config.	50 dB
Gain Variation with Temperature	3dB max over operational temperature range
P1dB Output Bandwidth	+12 dBm 1164 – 1300 MHz 1559 – 1610 MHz 1525 – 1559 MHz

Out of Band Rejection	<800 MHz	>60 dB
	<900 MHz	28 dB
	<1000 MHz	15 dB (min)
	1430 MHz	25 dB
	>1690 MHz	>60 dB
	>1710 MHz	<5 ns

Group Delay variation

<5 ns

Antenna

Antenna Gain	5 dBic to 7 dBic (all frequencies)
Efficiency	>70%
Phase Centre Variation	± 1 mm / 0.04 in
Phase Centre Offset (RMS)	± 0.2 mm / 0.008 in
IGS model available	Yes
NGS model available	Yes

Mechanicals & Environmental

Antenna Reference Plane (ARP)	Bottom of 5/8" thread
North Orientation Indicator	Mark on radome above
Operating Temperature Range	-40° C to +85° C
	-40° F to +185° F
Weight	820g / 1.8 lb (conical radome)
Mounting Thread	5/8" x 11 TPI female
Connector	TNC Female
Environmental	IP67, RoHS, WEEE and REACH compliant
Shock	vertical axis: 50 G other axes: 30 G
Vibration Certification	MIL STD 810D CE, RoHS, WEEE



DIMENSIONS

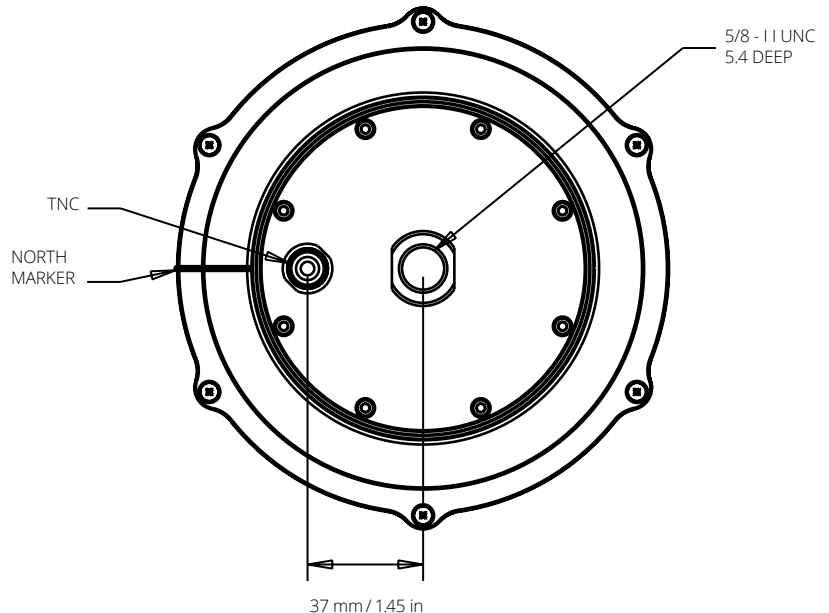
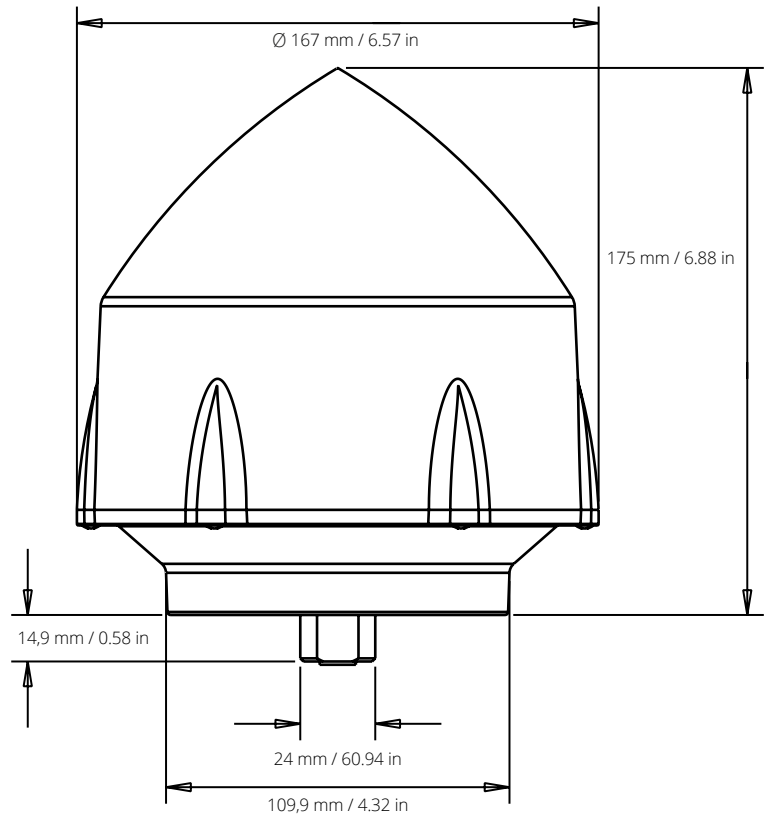

Performance Measured @ Vcc = 3V, and Temperature=25° C / 77° F

• Specifications subject to change without notice. Certain features and specifications may not apply to all models. © 2018 Septentrio NV. All rights reserved.

SSNBBR 64/07/2018

JOSEF ATTENBERGER GMBH

Wasserburger Straße 7
D-84427 Sankt Wolfgang
Telefon 08085-930 510
Fax 08085-930 550

Freecall
Telefon 0800-2883623
www.attenberger.de
info@attenberger.de

